



eSUN3D



iSUN3D

**GLOBAL LEADING BRAND
OF 3D PRINTING POLYMERS**

www.esun3d.net

eSUN Industrial Co., Ltd.

Tel: +86-755-26031979

E-mail: bright@brightcn.net

eSUN[®]

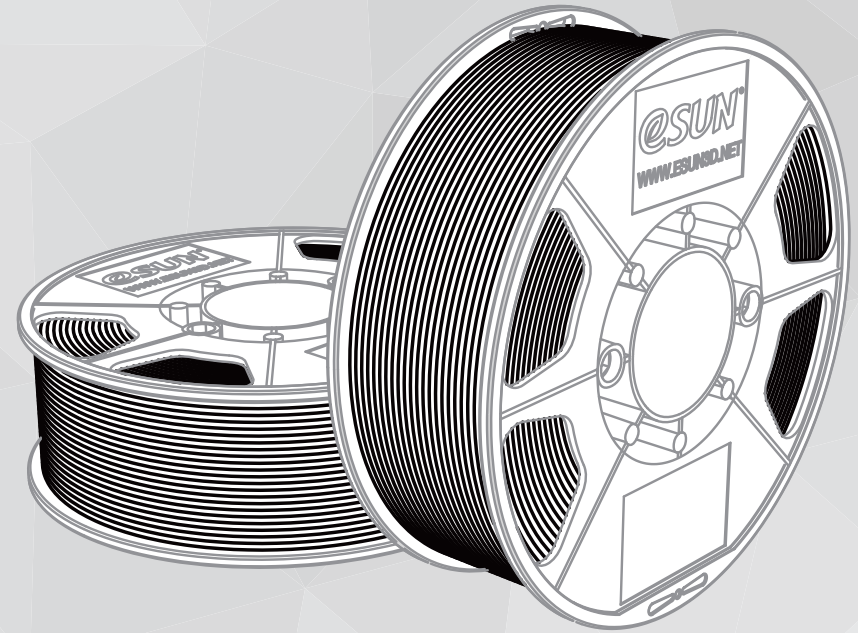

**3D Printer Filament
User Guide**

GLOBAL LEADING BRAND OF 3D PRINTING POLYMERS

PLA Series (including PLA+ / Color Changing / Wood / eSmooth / eBamboo / PETG)

Applicable Printer: General	Printing Temp.190-220°C	Bed Temp. 60 ~ 80°C
(BuildTak/Kapton Tape Recommended) . For better modelling effect, please use Blue Masking Tape and do NOT heat the print bed.		
Speed: 40 ~ 60mm/s	Travel Speed: 80 ~ 150mm/s	Filling Rate: 10 ~ 100%
Wall Thickness: ≥2 Layers	Cooling Wind Speed: 50 ~ 100%	/
Alcohol is applicable to the finishing process of eSmooth.		

ABS / ABS+ / eABS MAX / HIPS / eASA

Applicable Printer: Printer with Hot Bed & Enclosed Chamber	Printing Temp.220-260°C	
Chamber Temp.80°C	Bed Temp.90 ~ 110°C (BuildTak/Kapton Tape/PEI Orifice Plate)	
Print Speed: 40 ~ 60mm/s	Travel Speed: 80 ~ 150mm/s	Filling Rate: 10 ~ 50%
Wall Thickness: ≥2 Layers	Cooling Wind Speed: 0 ~ 10%	/
Acetone is applicable to the finishing process of ABS.		

ePA / ePA-CF / ePA-GF / ePC

Applicable Printer: Printer with Hot Bed & Enclosed Chamber	Printing Temp.230-260°C	
Chamber Temp.65°C	Bed Temp.80 ~ 90°C (PEI Orifice Plate/Blue Masking Tape) , 50 ~ 80°C (Glue stick)	
Print Speed: 40 ~ 60mm/s	Travel Speed: 80 ~ 150mm/s	Filling Rate: 10 ~ 100%
Wall thickness: ≥2 Layers	Cooling Wind Speed: 0 ~ 50%	/
Baking the ePA filament including ePA-CF & ePA-GF with temperature ranges from 90°C to 100°C for 6 hours if it absorbs moisture.		

eFlex / eLastic / eTPU-98A / eTPU-95A

Applicable Printer: Near-End Seamless Extruder	Printing Temp.210-240°C	
Bed Temp.No Heat (Kapton tape/PET tape)		
Print Speed: 20 ~ 40mm/s	Travel Speed: 80 ~ 150mm/s	Filling Rate: 20 ~ 100%
Wall Thickness: ≥3 Layers	Cooling Wind speed: 100%	/

Bronze / eCopper / eAL-fill / eSteel

Applicable Printer: General	Nozzle Diameter: ≥0.6mm	Printing Temp.190-220°C (Bronze180-210°C)
Bed Temp: 60 ~ 80°C (BuildTak / Kapton Tape Recommended) . For better modelling effect, please use Blue Masking Tape and do NOT heat the print bed.		
Print Speed: 40 ~ 60mm/s	Travel Speed: 80 ~ 150mm/s	Filling Rate: 50 ~ 100%
Wall thickness: ≥3 Layers	Cooling Wind Speed: 50 ~ 100%	/
Tip: eCopper Surface Finish Process: Raw Emery Paper →Fine Sandpaper→Soft Cloth Wheel (Dusting) →Polishing Liquid→Soft Cloth Wheel. eAlfill/ eSteel Finishing Process: Raw Emery Paper → Stainless Steel Soft Brush		

PVA / ePVA+

Applicable Printer: Double Nozzle	Printing Temp.190-210°C	Bed Temp.60 ~ 80°C
(Kapton / PET tape) .For better modelling effect, please use Blue Masking Tape and do NOT heat the print bed.		
Print Speed: 40 ~ 60mm/s	Travel Speed: 80 ~ 150mm/s	Support Filling Rate: 50 ~ 100%
Support Critical Angle: ≤45°	Gap Between the Support and Model: 0	
Tip: Baking the filament with 60°C for 4 hours if it absorbs moisture.If air bubble occurs, please prolong the baking time or increase the temperature within the range of 80°C.		

eSUN Industrial Co., Ltd.

GLOBAL LEADING BRAND OF 3D PRINTING POLYMERS

ePEEK

Applicable Printer: Printer with hot bed & enclosed chamber	Printing Temp.380-450°C	
Chamber Temp.90°C	Bed Temp.80 ~ 110°C (Kapton Tape / PEI orifice plate)	
Print Speed: 40 ~ 60mm/s	Travel Speed: 80 ~ 150mm/s	Filling Rate: 50 ~ 100%
Wall Thickness: ≥2 Layers	Cooling Wind Speed: 0 ~ 10%	/
Annealing Process: Put in oven with temperature ranged from 150°C for 1 hour to 200°C for 1 hour or 150°C for 0.5 hour.		

☆ **GUIDELINES**

- 1.Please do NOT start your print before checking your printer runs normally and keep the print bed and nozzle at a proper distance, including the clean of residuals on nozzle.
- 2.Please ensure the filament is tangle-free before use and is secured each time after the end of printing.
- 3.MAKE SURE don't let the open-end loose and spring back to the spool. It could lead to cross under unnoticed and could eventually get stuck. ALWAYS secure the open-end. If it springs back accidentally, you will need to TIGHTLY unwind for 20 feet to fix any tangles formed.
- 4.Printing temperature may varies on different printers, extruding the filament beforehand for testing the best printing temperature that is measured by smooth extrusion, which should be proper otherwise may generate the possibility of strings.
- 5.Near-end Extruder: Retraction distance 1-3mm, Retraction speed 20-30mm/s.
Far-end Extruder: Retraction distance 4-6mm, Retraction speed 40-60mm/s.
- 6.Please clean the feeding gear regularly with a toothbrush.
- 7.Nozzle wear is easier to happen in the glow in the dark filaments.
- 8.Please ensure the constant temperature in printing area in case the occurrence of edge warping and cracking due to the fast cooling rate and excessive shrinkage rate.
- 9.For small print, additional fans are recommended to facilitate the cooling including the flexible filaments for averting undesirable shape result from slow cooling at local area.
- 10.0.6mm or bigger nozzle is required to print the metal filaments otherwise it is to be blocked. And the nozzle should be cleaned with cleaning filament or PLA after long-time printing in case of nozzle jam.
- 11.The common printer throat is equipped with in-built Teflon tube designed for resisting the blockage, and the printing temperature should be within 260°C.
- 12.Printing parameters correlate with the performance, size of print, complexity and characteristics of filaments,therefore the best print result demands users to find out the printing parameters that work with printer and filaments perfectly.

△ **TROUBLESHOOTING GUIDE**

Questions	Cause Analysis	Directions
Blocked Nozzle	Diameter: over thick/thin	Replace filament
	Printer: Gear clearance jammed	Clean gear
	Gear: abrasion /insufficient bite force	Clean gear, strengthen bite force
	Throat: deformed Temperature: too low / filament burned or carbonized	Change new Temperature rise / Clean the nozzle with thin iron stick
Stringing	Temperature: too high	Lower printing temp properly
	Remnants surrounded the nozzle Oozing when printer travel	Clean the nozzle before printing Raise travel speed,retraction speed and retraction distance
Dark Spot	Remnants surrounded the nozzle	Clean the nozzle before printing
	Impure filament	Change pure filament
Print Offset	Belt loose	Adjust the belt position to even out the belt tension
	Polish rod being dry Malfunction of drive coupler	Check the rods are clean and apply some oil Repair or change a new one
Print Edges Are Warping	The space between nozzle and print bed is big	Narrow the space
	Weak viscous force of coating on print bed	Change the coating or adhesive tape change your print bed to one that offers better adhesion
	Print bed temperature too low	Increase the bed temperature
	Bottom layer printed too fast Shrinkage rate is too big / cooling too fast Low Print temperature and fluidity	10-20mm/s Keep the temperature, Slow down the cooling wind speed / close the cooling fan. Improve the printing temperature of first layer properly
Cracking	High shrinkage rate / fast cooling speed	Increase print temperature / Keep the temperature / Reduce print speed / thickness
Bevel molded with failure	Cooling too slow / printing speed is too fast	Accelerate the cooling / reduce printing speed / increase wall thickness and filling rate

eSUN Industrial Co., Ltd.